

# Relay Information

The two most common methods of controlling a process are “on/off” and “proportional” control. In on/off control, relay setpoints are defined as either high or low limits on the process variable. When the measurement value reaches a limit the relay is energized, typically for the purpose of opening a valve or starting a pump to introduce a chemical reagent to the process. This should cause the measurement value to change in the direction of the setpoint as shown in these on/off control diagrams:

High limit on/off relay control

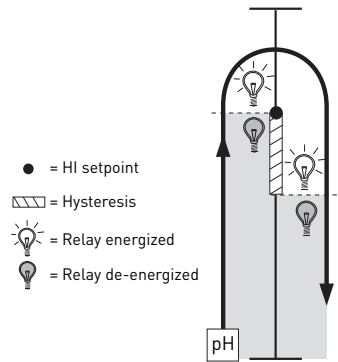

Low limit on/off relay control

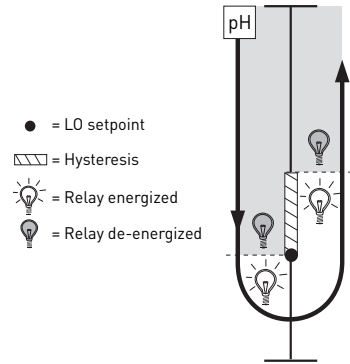

Notice the relay will not de-energize until the setpoint is exceeded by the hysteresis value. This is a programmable value and is primarily used to prevent “relay chatter”, which occurs if a relay is set to energize and de-energize at the same value. Because of hysteresis, and because reagent delivery is fairly constant while the relay is energized, a condition known as “overshoot” is inherent to the on/off control method. Overshoot refers to the introduction of more chemical reagent than is absolutely necessary for achieving a desired adjustment to the process value, and can be expensive over time.

Proportional control is a popular alternative to the on/off control method. This method typically makes use of variable-rate metering pumps to reduce overshoot and improve precision. Establishing a proportional control scenario requires the selection of setpoint(s), deviation range(s) and maximum pulse rates.

The example shown here illustrates how two relays in “pulse mode” can be used to proportionally control pH within a desired range, or to a single setpoint. This is called “Dual Proportional Control”. Of course, a single relay in proportional pulse mode can be used to establish a high or low limit and will also reduce overshoot.

Metering pumps are idle at and between setpoints. When a setpoint is exceeded, the pump begins delivering reagent at a rate proportional to the difference between the measurement value and the setpoint. The larger the difference, the faster the delivery. The programmed deviation value defines how quickly the maximum pulse rate is reached. Depending on the input requirements of the metering pump, proportional control can also be accomplished with scaleable 4 to 20 mA outputs instead of pulsing relays or open collectors.

## Dual proportional pulse relay control

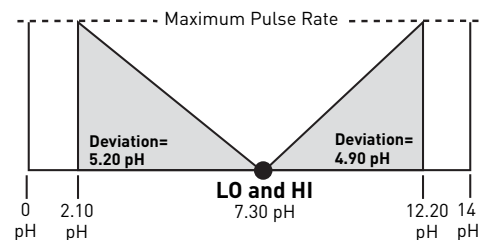
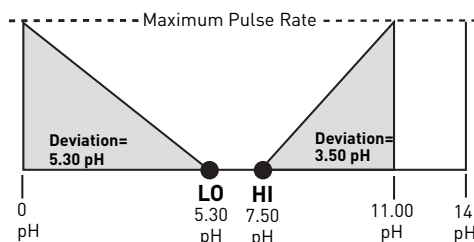

# Open Collector Output

Many Signet instruments and sensors feature “Open Collector Outputs” for purposes of signal transmission, alarming, control signal output, etc. Although such outputs allow for a lot of wiring flexibility, care must be taken not to destroy the circuits via incorrect polarity, over-voltage, transients or current overload. Below is an explanation of proper wiring and dimensioning of related circuit components. Please note that the following recommendations may or may not apply to other manufacturer’s equipment.

## 1. Function

Open Collector (“OC”) outputs are low powered, solid state switches. Although the term “Open Collector” stipulates the use of bipolar transistors (NPN-type or PNP-type) as a switch, nowadays Field Effect Transistors (FET or MOSFET) are used. Unlike electromechanical switches (e.g. pushbuttons or dry contact relays) these OC switches are very fast, use little power, are inexpensive, do not bounce and do not wear. However, OC’s are also more limited in terms of voltage and current rating as well as being polarized (i.e. they have a “plus” and “minus” terminal and thus DC only switching capability). They are less tolerant to overload abuse than electromechanical devices. Usually these switches have higher resistance and voltage drop.

## 2. Sensor Wiring

A typical example of the need for high speed switching capability is the OC frequency output of Signet flow sensors like 3-2536 or 3-2540. Signal frequencies can reach several hundred pulses per second while voltage and current requirements are small enough, allowing the use of a transistor switch. For each output pulse this switch connects the signal output to the negative supply or ground terminal of the sensor and is therefore an “NPN” style output. Signet does not produce sensors with PNP style outputs (which connect the signal output internally to the positive supply terminal).

Most indicating instruments or control system inputs require a signal voltage of 0 to 5 V (TTL or CMOS logic levels) or 0 to 24 V. Therefore, Open Collector output circuits must be complemented with a “Pull-Up-Resistor” to function properly. Please see the following example diagram for wiring with a PLC input:

Do not exceed the absolute maximum voltage rating of the OC output as listed in the sensor specifications, normally 27 or 30 Volt, DC only. This includes changes to power line fluctuations, transients or power supply instability, otherwise damage to the OC will occur.

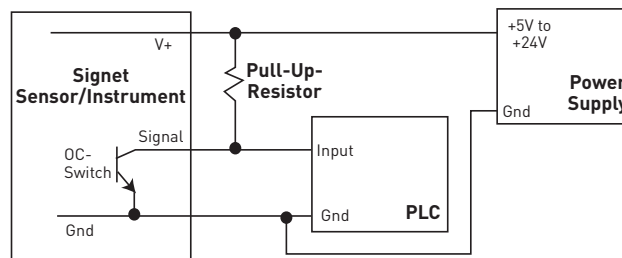

Please note that the voltage connected to the positive sensor supply (V+) must correspond to the required high-level PLC input voltage (i.e. if the high-input voltage of the PLC is 24 V, then the pull-up must be supplied with 24 V). If the input is “TTL-Level” or “CMOS-Level”, that means 5 V for high level, then the pull-up should not be connected with a supply higher than 5 V.

Signet instruments already have the pull-up-resistor and the sensor power supply built into the instrument. No external pull-up-resistors are required.

# Open Collector Output (continued)

## 3. Instrument Output Wiring

Open collector control and alarm outputs on Signet instruments (i.e. ProcessPro® or ProPoint® series) are electrically isolated from the instrument's power supply. That means these can be used in the above mentioned NPN configuration as well as in PNP configuration, if required. Below are a few sample circuits:

- PLC Wiring "NPN" style

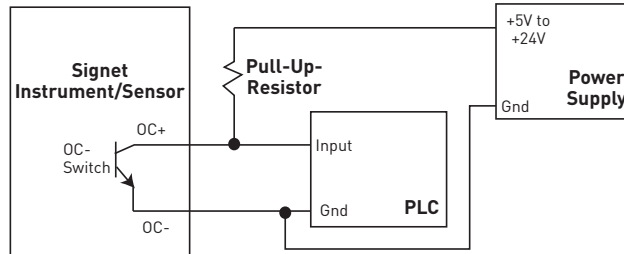

- Alarm circuit or alarm lamp wiring to a single Signet instrument

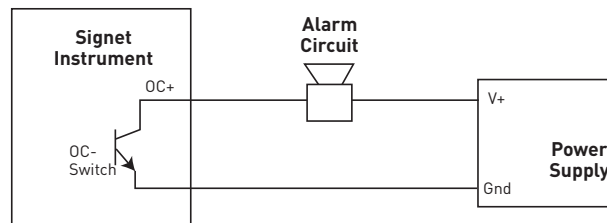

- Alarm circuit or alarm lamp wiring to serve multiple Signet instruments  
- Triggers the alarm if any one of the instruments open collector outputs are on.

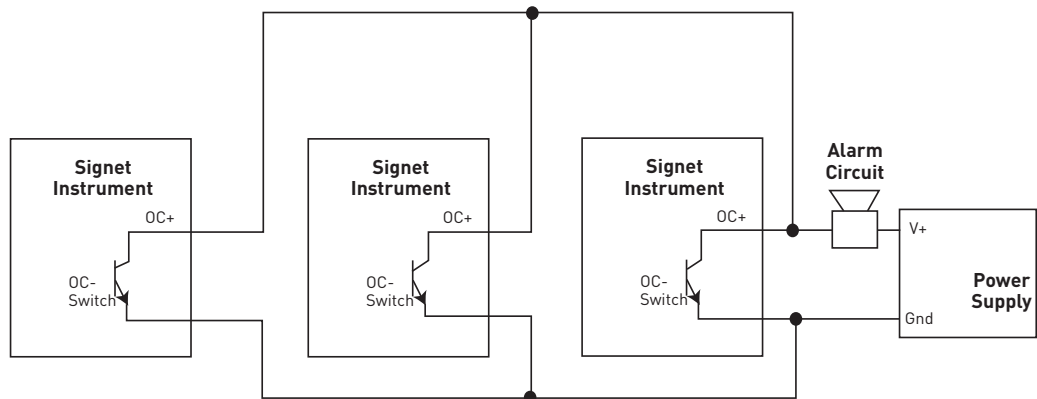

# Open Collector Output (continued)

## 4. Voltage and Current Limitation

As mentioned before, the supply voltage in the OC output circuit MUST be limited to the specified maximum OC voltage (see operating manual for specific instrument). The use of a quality regulated 5 V, 12 V or 24 V (depending on the application) power supply is recommended.

The current through the Open Collector switch must be limited. Typical OC outputs allow only for 10 to 50 mA switch current (please consult manual). Exceeding this current limit can burn out the OC output components immediately. Please see the following section on how to dimension the loads.

## 5. Load and Pull-Up/Down Resistor Considerations

By utilizing basic arithmetic and Ohm's law, one can determine the safe limits of load resistance. When the OC switch is closed, almost the entire supply voltage is applied to the load, (i.e. the pull-up or pull-down resistor, the alarm horn input, a potential power relay coil or annunciator lamp). The resulting current through the load and through the OC switch, as well, can be calculated as:

$$(\text{Current}) = (\text{Supply Voltage})/(\text{Load Resistance})$$

- Example 1:

The supply voltage is 24 V and a pull-up-resistor of 10 k $\Omega$  is used. Current is  $24/10,000 = 2.4$  mA

(If the OC current rating is 10 mA, then in this example, it would be considered safe.)

- Example 2:

The supply voltage is 12 V and a horn with a resistance of 100  $\Omega$  is used. Current is  $12/100 = 120$  mA

(Even if the OC current rating is 50 mA, this load will damage the instrument)

## 6. Transient Protection

There are several "difficult" load cases that must be considered:

- Inductive loads:

These can be power relay or other solenoids, motors, alarm horn coils, etc. Such loads generate very high voltage spikes every time the load switches. If such a load is unavoidable, the use of transient suppression components, or Signet RC-filters (3-8050.396), or snubbers, wired parallel to the load is required. This is critical, as a single transient pulse may destroy the output.

- Capacitive loads:

This type of load should be rare but can occur if the load contains an internal power supply/regulator that is fed from the output circuit. In such a case, it must be assured that the in-rush current does not exceed the OC current rating.

- Incandescent lamps:

Such lamps have a very high start-up current until the filament glows and the current settles to the specified value. The use of incandescent lamps on an OC output is not recommended. An LED type annunciator should be used instead.

## Open Collector Output (continued)

### 7. “Active High” and “Active Low” Setting

Depending on the desired function of the circuit attached to the OC output, it may be necessary to have the OC output switch turned “on” or “off” when the criteria for the activation of this output are met.

By default, Signet instruments are set to operate in “active low” mode. This means when the user-defined condition for the activation is met (e.g. exceeding of an alarm limit) the OC switch is turned “on”. If wired as standard “NPN-style” output (see previous page) the logic level of the attached control system or PLC input consequently becomes “low” logic level.

If a high input logic level is required for activation, it can be accomplished by changing the OC output function to “active high” in the menu system of the instrument. Most Signet instruments allow for this option.

### 8. Fail-Safe Behavior

No matter what the setting, most OC outputs of Signet instruments turn off when the instrument loses power. This must be taken into account when evaluating system failure consequences. If the system layout requires a “closed” or “on” condition for the output in case of power loss, a mechanical dry contact relay (NC contacts) must be used instead of the OC output.

# Open Collector Output (continued)

## Control Outputs

Many Signet products offer control outputs that can be categorized into three categories: Mechanical Relay, Solid-State Relay and Open Collector. Each control output offers benefits and limitations based on the application requirements. See below for comparisons.

---

### Open Collector

Benefits:

- Longer life than a Mechanical Relay
- No moving parts
- Can switch DC voltage only (typically < 30 VDC)
- Faster ON/OFF switching capabilities than Mechanical Relays

Considerations:

- Can only be used with DC voltage
  - Polarity very important when wiring
  - Not recommended for use with inductive loads
  - Lower voltage and current ratings than Mechanical Relays
  - Typically should not apply current > 25 mA
- 

### Solid-State Relays

Benefits:

- Has isolated outputs (optically)
- Can switch DC voltage (typically > 30 VDC)
- Can switch AC voltage (typically > 42 VAC) 50 mA DC / 50 mA AC
- Longer life than a Mechanical Relay
- No moving parts
- Faster ON/OFF switching capabilities (Equal rise/fall times)

Considerations:

- Not recommended for use with:
  - Inductive loads (ex. Solenoid, Pumps)
  - If using inductive loads, snubbers (RC Filter) can prevent IC damage
  - Lower voltage and current ratings than Mechanical Relays
- 

### Mechanical Relays

Benefits:

- Can switch line voltage (typically > 120 to 240 VAC)
- Can switch DC voltage (typically > 30 VDC @ 5A)
- Has a large current rating (typically 5 A)
- Larger voltage and current ratings than Solid-State Relay and Open Collector Outputs

Considerations:

- Slower ON/OFF switching capabilities than Solid-State Relay and Open Collector Outputs
- Mechanical contacts can burn/wear over time
- Snubbers (RC Filter), Signet 3-8050.396, can prolong contact life

# RC Filter

RC Filter kits are recommended when using a Signet transmitter or controller with mechanical relays, and/or the external relay module 3-8059 to switch on and off inductive loads. Signet RC filter kits provide protection and extend the life of the relay by preventing premature wearing of the relay contacts, usually caused by voltage/current arcing and line noises generated by the activation and deactivation of mechanical relays.

RC filter kit (3-8050.396) comes with two RC filter assemblies.

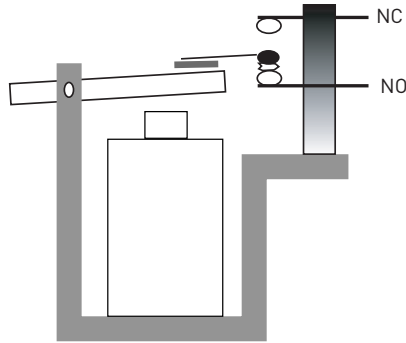

During the activation and deactivation of a relay, a spark can be generated on the surface of the relay contacts. This spark, over a period of time, melts the surface of the contacts which will prevent the contacts from making a physical connection

Figure A is suitable for AC and DC applications.

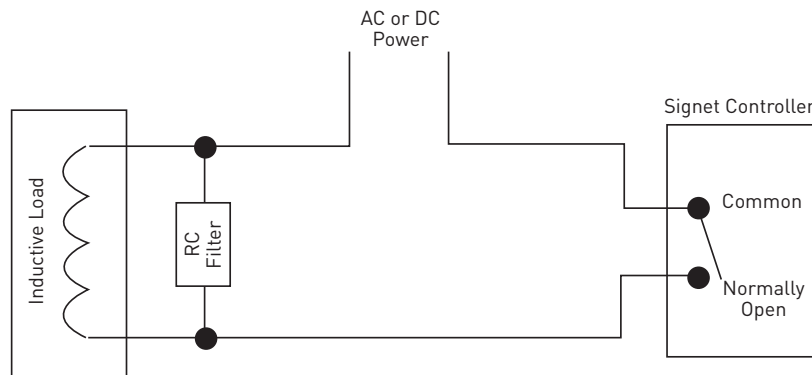

**Fig. A**

Figure B is also suitable for AC and DC applications. However, if this configuration is used with an AC power source, verify that the impedance of the load is less than the impedance of the RC filter; current leak through the filter may occur and cause the device to be constantly on.

- $R = 47 \Omega$
- $C = 0.01 \mu F$

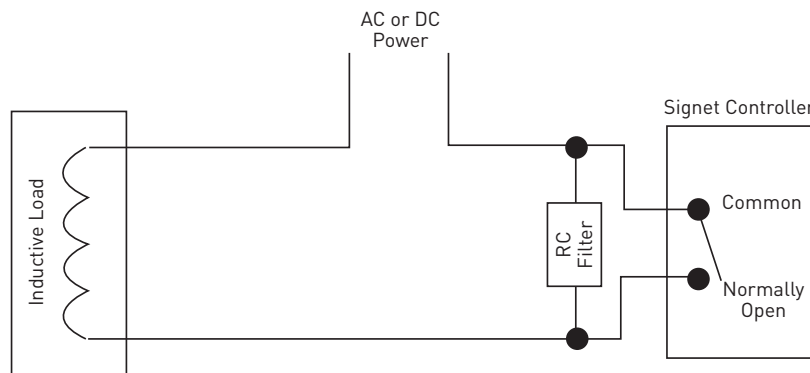

**Fig. B**